

Data sheet BR9G090I



Constructive Features

- cooking vessel in stainless steel AISI 304 (bottom thickness 12-15 mm and wall thickness 2 mm). Vessel with manual tilting on front part with worm screw controlled by a handwheel
- balanced lid in stainless steel AISI 304 (thickness 10/10) equipped with ergonomic handle
- outer cover in stainless steel AISI 304, fine satin finish (thickness 10/10)
- adjustable feet in stainless steel AISI 304 to ensure levelling

Functional Features General

- heating by means of stainless steel high efficiency tube burners. Ignition by means of spark system (piezo) and pilot flame. Thermostatic valve with thermocouple safety system and temperature adjustment with electromechanical thermostat from 50 °C to 300 °C. Vat filled with water by means of tap and swivel hose fixed to the chimney
- heating interruption in the tank overturning phase

Panel Board Functions

- thermostatic gas valve
- pilot burner ignition button (piezo)
- temperature setting with electromechanical thermostat
- manual cock for vat filling
- tilting and manual return of cooking vessel

Optionals

- BAR0010 - KIT 4 WHEELS BR..

Accessories

- NOT PRESENT

Certificates



Planner

.....

.....

.....

.....

.....

.....

.....

.....

.....

.....

Firex Srl reserves the right to make modifications to the products without prior notice. All information correct at time of printing - 2021.03.25

* REG. - 5 ; + 55 mm

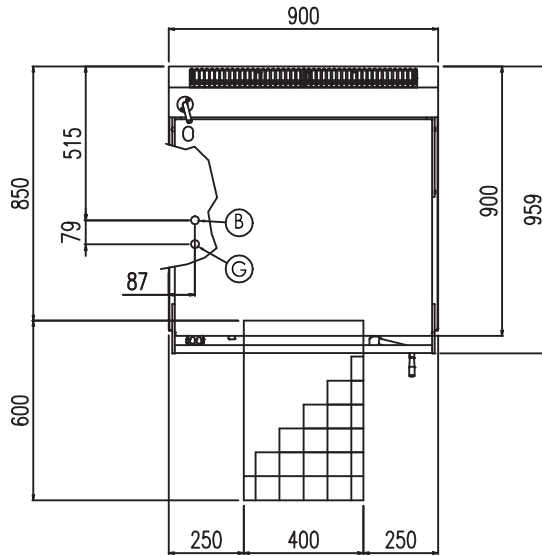
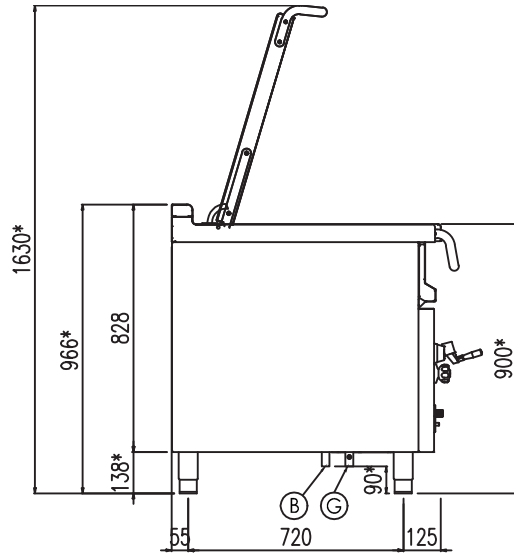
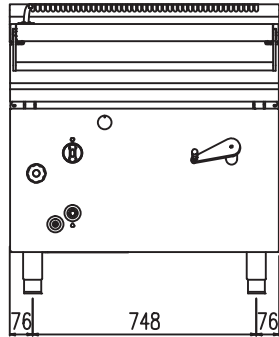

Dimensions weights and capacities

Width	900 mm	Vessel width	798 mm	Capacity	70 lt
Depth	900 mm	Vessel depth	564 mm	Cooking vessel surface	45 dm ²
Height	970 mm	Vessel height	200 mm	Weight	152 kg

Water connection

Water pressure	50÷300 KPa	Cold water inlet (B)	1/2"
----------------	------------	----------------------	------

Gas connection

Gas connection (G)	3/4"	Gas power	20 Kw
--------------------	------	-----------	-------